

# Development of an HMI Based Smart Power Quality Display

<sup>1</sup>Sachin V. Shelar, <sup>2</sup>Onkar Bobde, <sup>3</sup>Deepjyoth Singh Makan, <sup>4</sup>Nayan Kulkarni, <sup>5</sup>Rajeshwari Kamath

<sup>1</sup>Assistant Professor, A.I.S.S.M.S. Institute of Information Technology, Pune, Maharashtra, India

<sup>2,3,4,5</sup>Student, B.E., Electrical Engineering, A.I.S.S.M.S. Institute of Information Technology, Pune, Maharashtra, India

**Abstract** - In recent times the modernization of industries has led to the increase of non-linear components in electrical circuits, usage of which has led to a decrease in the power quality; which further translates into losses both financially, electrically, and in some cases, it may also lead to loss of life. Thus, identifying, analyzing, and mitigating power quality issues have become a necessity. Power quality meters can measure some power quality parameters whereas a power quality analyzer can measure and give actionable insights to the user; however, power quality analyzers cost a fortune to the general consumer whereas a power quality meter costs significantly less. The aim of this project was to cover this gap by creating a user-friendly environment around a power quality meter using an HMI which will help the consumer to get actionable insights as well as a graphical representation of power quality parameters. In this project, a smart and user-friendly Power Quality Display, capable of providing graphical insights to the user has been developed using Janitza UMG 96 PQ-L (base power quality meter) and Delta 107EV HMI (Touch Screen HMI). The software DOPSoft has been used to program the HMI and the transfer of data between the meter and HMI has been done with the help of Ethernet.

**Keywords:** Power Quality, Power Quality Analyzers, HMI, Graphical User Interface.

## I. INTRODUCTION

Power Quality has become a catchword in the power industry. The modernization of industrial workspace in the past few decades has led to an increase in the use of non-linear loads. The ease of manufacturing and the precision offered by Power Electronics devices have made them an indispensable part of the Electrical Energy field. Such devices are known to draw currents in abrupt pulses. These pulses lead to distorted (non-sinusoidal) current waveforms which circulate in the system and cause power problems affecting the grid and loads connected to it. With automation making its way into even small-scale industries there arises the need to keep in check the power quality as per standards for the benefit of both the consumer and the utility which is supplying the electrical

energy. The performance of the user's equipment is directly dependent on the quality of power supplied. Therefore, there is a need to identify the problem if any and collect data before solving it.

The first step of solving any power quality problem is to measure the parameters like voltage, frequency, and power factor, harmonics and transient as per the standards stated for them like the IEEE 1159 or EN 50160 [3]. The second step is analyzing this data and finding out when these values have fallen out of the normal range and registering it as an event.

The difficulty arises when one tries to get a device that is capable of doing so within their budget. The power quality analysers that already exist in the market are very expensive and small industries cannot afford to invest in them.

The aim was to solve this difficulty by providing a solution that is both budget-friendly and a more user-friendly way for the operator or engineer to get power quality data and actionable insights from it.

## II. BLOCK DIAGRAM OF THE SYSTEM

Electric loads vary in size and specifications according to the user requirements; these load shave transformed with time into loads that deteriorate the power from its ideal quality while also being sensitive to low power quality. To measure and analyze this a power analyser - Janitza UMG 96 PQ L is connected across the load to measure various parameters like voltage, current, frequency, power factor, harmonics and its order and so on.

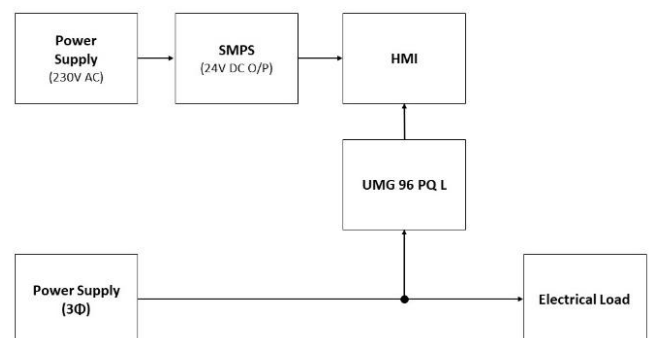

Figure 1: Block Diagram of the System

The data of the parameters mentioned above can be seen on 96 PQ-L live by browsing through the screens using the various options via the buttons provided on it. However, this doesn't allow the user to see previous data over a long range of time and the screen preinstalled on it is not very user-friendly in terms of the contrast and brightness of the display.

Thus, an HMI is connected to the meter which serves as both a better screen and a place to store and view previous readings. The data from 96 PQ-L is transferred over to the HMI using serial port communication protocol RS 485 or Ethernet. Furthermore, the data from the meter which gets accumulated in the HMI can be used to show various graphs depicting various trends in the consumption of power and the occurrence of events; making it easier for an individual to get actionable insights from it over time.

The HMI requires a constant DC input of 24 V. Therefore, an SMPS is used to provide this constant input to the HMI irrespective of the variations in supply voltage.

### III. HARDWARE SPECIFICATIONS AND DESIGN

#### 3.1 Power Analyser (Janitza UMG 96 PQ L)

Janitza 96 PQ L was chosen as the base meter for this project. It is a multifunctional network analyser and is suitable for: measurements and calculations of electrical quantities such as

- Voltage (417V/720V for 3 phase-4 wire system, resolution of 0.01V)
- Current (up to 6Amps with a resolution of 0.1mA)
- Power (up to 12.6 kVA)
- Energy (up to 999 GVAh after which it becomes 0W)
- Harmonics (up to 63rd order)
- Sampling rate of 13.6kHz

For Communication between devices, the UMG 96 PQL provides 2 options: RS 485 – Modbus protocol and Ethernet. It requires a supply of 230V AC, 50/60Hz for it to function. [9]

#### 3.2 Human Machine Interface – HMI DOP (107-EV)

A Human Machine Interface acts as a dashboard between a person and the machine. An HMI from the Delta brand was chosen as the display for this project.

- Display type-7" TFT LCD
- Resolution (Pixel)- 800 x 480
- Display size- 154.08 x 85.92 mm
- Flash ROM – 256 MB; RAM- 256 MB
- Serial communication port – 3 ports: RS-232, RS-232/RS-485 and RS-422/RS-485
- Operating Voltage DC +24 V (±15%) [8]

#### 3.3 Shielded RS 485 Cables

The project uses RS 485 serial interface to efficiently and cost-effectively send data to the HMI from the meter. This is achieved by connecting the meter and the HMI with a 3-core shielded cable which prevents unwanted external interference. As per the datasheet of the HMI, pins 1 and 6 of the DB9 connector were connected to the cable's positive and negative terminals respectively.

#### 3.4 Ethernet Cable

A Category 6 (Cat-6) Cable with RJ45 connectors was used to establish the connection between the devices.

#### 3.5 Switched Mode Power Supply (SMPS)

A Switched-Mode Power Supply (SMPS) is a way to regulate the required power supply in such a manner that its load is least affected by the voltage fluctuations in the source. The project uses Shavision G31-60-24SMPS to power the HMI separately from the entire system and to protect the HMI from faults if any.

#### 3.6 Circuit Diagram

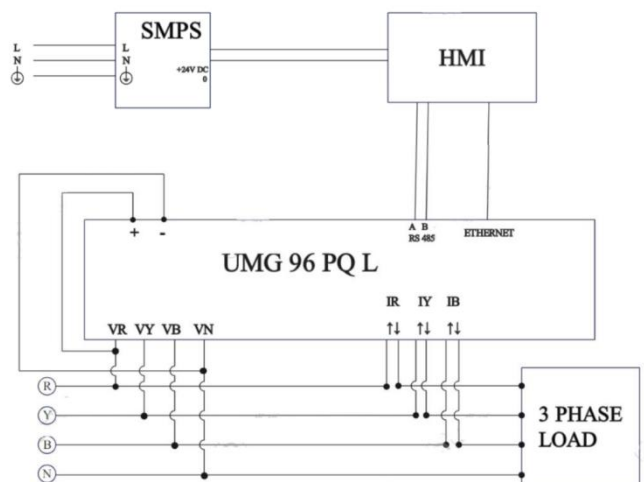

Figure 2: Circuit Diagram of the Smart PQ Display

#### 3.7 Casing/ Enclosure

The Delta DOP 107EV HMI is enclosed in a PVC case of dimensions 300 x 250 x 120 mm. The PVC case is from the brand Posina and is water-resistant. (IP 65).

The supply to the HMI is provided through the SMPS. The SMPS provides a constant 24V DC output which is the required input of the HMI. The SMPS is placed inside the case.



Figure 3: Front view of the Smart PQ Display

On the left side, (Ref. Figure 4) there are communication ports – COM 1 and COM 2 and USB Ports and LAN(Ethernet) port. On the right side,(Ref. Figure 4) there is a power input terminal (230V AC) and a switch.



Figure 4: Side Views of the Smart PQ Display

#### IV. SOFTWARE DESIGN

DOPSoft software is used to program and build the graphical interface of Delta HMI. (Version 4.00.11) With DOPSoft, it is possible to design the screen of an HMI as the user demands wherein it is also possible to create a user interface comprising of various types of charts, tables, and graphs from the data it stores sent by the meter.[7] It is also possible to manage memory. Before designing a screen in the DOPSoft, the HMI model needs to be selected.

##### 4.1 Establishing Communication

To establish communication between the HMI and the meter using RS-485 protocol, some communication settings were done. The Baud Rate of both devices was matched. Data bits, stop bits, and parity bits were set to 8,1 and none respectively.

To establish communication between the two devices using Ethernet, TCP/IP controller was selected and the IP address 172.16.111.239 and port 502 were selected. The IP address of the meter and that inputted in DOPsoft must match. The addresses must be in hexadecimal format.

##### 4.2 Designing a screen using DOPSoft

Grey was selected as the background colour for all the screens of the Smart PQ Display. This colour enables good contrast and also prevents any glare.

The home screen (Ref. Figure 5) of the HMI has the college and PQ Cell logo in the center. There are three options on the right side: Numeric Display, Graphical Representation and 'Eject USB Drive'. The present date and time are shown in the left bottom corner. The button in the bottom center is to access the next page.



Figure 5: Home screen of the Smart PQ Display

The bar graph needs decimal values to work. Since the values passed on by the meter are of floating type, this macro-programming (Ref. Figure 6) is applied to convert floating numbers into an integer (decimal numbers).

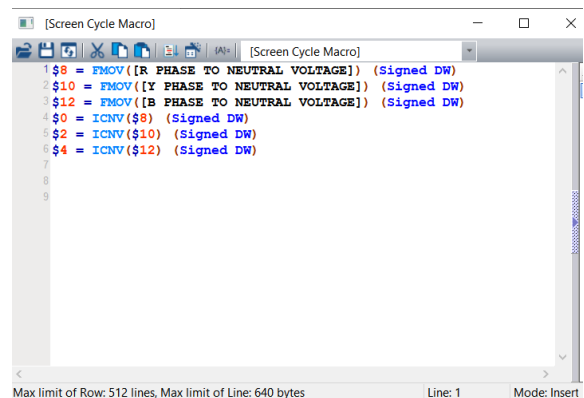

Figure 6: Screen Macro for Bar Graph

There are 13 screens that display data in graphical form – Parameters displayed are Phase Voltages, Line Voltages, Current, Active Power, Reactive Power, Apparent Power, Power Factor, %THD Voltage, % THD Current, %TDD Crest Factor Voltage, and Crest Factor Current of all three phases. Voltage and Current Harmonics (up to 25th) of R, Y, and B phase and maximum monthly Active, Reactive and Apparent energy consumption.

Screens 2- 20 display data in numeric format.

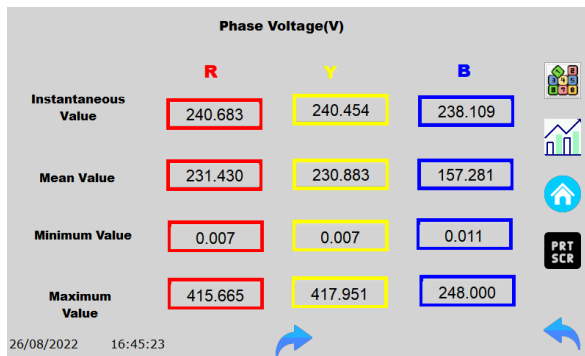

Figure 7: Representation of Data in Numeric Display

On Screens 2-20, if the Numeric Display element(icon) is pressed, it is redirected to Screen 2. On Screens 2-20, if the Graphical representation element(icon) is pressed, it gets redirected to the respective graph.

On Screens 21-33, if the Graphical representation element(icon) is pressed, it is redirected to screen 21. On Screens 21-33, if the Numeric Display element(icon) is pressed, it gets redirected to the screen showing the same data in the numeric display format.

On clicking on the Home Button (Icon), it is redirected to the Home Screen- Screen 1.

## V. RESULTS AND DISCUSSIONS

- The HMI was able to display data in a way that is more user-friendly than the meter by improving the meter's readability and contrast.
- Various parameters both general electrical and parameters specific to power quality (%THD, %TDD etc.) can be seen almost instantaneously with the use of Ethernet.
- The ability to manually record an event is also present by clicking on the "screenshot" button which saves a copy of the screen in PNG format in the USB drive that can be later viewed.
- The system as a whole can allow the user to perform partial remote monitoring where the data is stored in a USB, which can be analyzed during routine maintenance.

## VI. CONCLUSION

The system is a great tool to introduce the basic terms of power quality and how it affects electrical parameters to new engineers using a single device to display all of it. The system made can be used to create an environment where someone with little knowledge can also understand if and when there is a breach of power quality parameter values beyond permissible limits.

By implementing it in small-scale industry, it can lead to a better understanding of power quality; which can help them increase profits by taking appropriate steps. However, it is suggested that an expert is consulted before taking said steps as the system only indicates the fault but not the cause.

## REFERENCES

- [1] S.Khalid & B. Dwivedi, "Power quality issues, problems, standards & their effects in industry with corrective means." International Journal of Advances in Engineering & Technology ©IJAET ISSN. 1. 2231-19631, 2011
- [2] P. Alexberg & M H. J. Bollen, "International Standards for Power Quality Measurement Systems"
- [3] C. Andrus III, "Understanding IEEE 1159 Definitions [White Paper]" Power Monitors. Inc.
- [4] C. Gong, "Human-Machine Interface: Design Principles of Visual Information in Human-Machine Interface Design," 2009 International Conference on Intelligent Human-Machine Systems and Cybernetics, 2009, pp. 262-265, Available: 10.1109/IHMSC.2009.189.
- [5] Janitza, "Energy Supply Quality Characteristics," manual, December 2021.
- [6] Janitza, "Power Quality Analyzer UMG 96-PA, UMG 96-PQ series" Modbus Address List and Formulary, August 2018.
- [7] Delta, "DOPSoft Operational Value," user manual, November 2018.
- [8] Delta, "DOP 107EV Datasheet," Installation Instructions, May 2018.
- [9] Janitza, "Power Analyzer UMG 96-PQ-L (From Firmware 1.0 / Hardware-Index 1)," datasheet, June 2021.
- [10] Shavison, "60 W Single Output SMPS" user manual and datasheet, May 2021
- [11] C. Sankaran, "Power Quality", CRC Press, LLC, New York, 2002.
- [12] Dugan, R.C., et al (2002) Electrical Power Systems Quality. 2nd edition, McGraw-Hill, New York.
- [13] Abdelhay A. Sallam; Om P. Malik, "Electric Power Quality," in Electric Distribution Systems, IEEE, 2011, pp.293-318, doi: 10.1002/9780470943854.ch7.
- [14] Power Quality In Electrical Systems – Blog [www.powerqualityworld.com/search/label/Power%20Quality](http://www.powerqualityworld.com/search/label/Power%20Quality).

#### AUTHORS BIOGRAPHY



**Sachin V. Shelar**, Assistant Professor, A.I.S.S.M.S. Institute of Information Technology, Pune, Maharashtra, India.



**Nayan Kulkarni**, Student, B.E., Electrical Engineering, A.I.S.S.M.S. Institute of Information Technology, Pune, Maharashtra, India.



**Onkar Bobde**, Student, B.E., Electrical Engineering, A.I.S.S.M.S. Institute of Information Technology, Pune, Maharashtra, India.



**Rajeshwari Kamath**, Student, B.E., Electrical Engineering, A.I.S.S.M.S. Institute of Information Technology, Pune, Maharashtra, India.



**Deepjyoth Singh Makan**, Student, B.E., Electrical Engineering, A.I.S.S.M.S. Institute of Information Technology, Pune, Maharashtra, India.

#### Citation of this Article:

Sachin V. Shelar, Onkar Bobde, Deepjyoth Singh Makan, Nayan Kulkarni, Rajeshwari Kamath, “Development of an HMI Based Smart Power Quality Display”, published in *International Research Journal of Innovations in Engineering and Technology - IRJIET*, Volume 6, Issue 8, pp 124-128, August 2022. Article DOI <https://doi.org/10.47001/IRJIET/2022.608015>

\*\*\*\*\*