

# A Review on Working of Heat Pump with Different Natural Resources

<sup>1</sup>T. Gopi Raju, <sup>2</sup>B. Sai Murali Krishna, <sup>3</sup>P. Sai Kiran, <sup>4</sup>R. Naga Babu, <sup>5</sup>V. Dileep Kumar, <sup>6</sup>Ms.K. Bhargavi

<sup>1,2,3,4,5</sup>Student, B.Tech., Mechanical Engineering, NRI Institute of Technology, Andhra Pradesh, India

<sup>6</sup>Assistant Professor, Mechanical Engineering, NRI Institute of Technology, Andhra Pradesh, India

**Abstract** - Due to the seasonal change's temperatures are varying in winter season some countries are having the '- degree. So, the engineers are developing the heat pumps which are used to maintain the human comfortable temperatures in the work area like (home, industries, companies, farms... etc.) In nature we have many kinds of heat sources to generate or introduce the heat to your systems (HP) sources like (earth crust, solar, wind, seas, ponds, depth areas. etc.) Heat pumps are considered as easy to use while utilizing the possibility of bringing low-temperature heat sources to a higher temperature. Thus, low-grade renewable energy sources (such as air, water, ground, solar), as well as waste heat sources; can be used to reduce the demand for fossil fuels and greenhouse gas emissions. Their big advantage is in the supply of both heating and cooling, they can be operated even in simultaneous mode. This means that virtually no heat is dissipated, making such systems truly efficient.

**Keywords:** heat pump, renewable energy sources, storage, working.

## I. INTRODUCTION

The conventional sources of energy are limited; also it cannot meet the increasing need of the common activities. Apart from this, some fossil energy would bring the problem of air pollution while the clean and renewable energy technology as shown in below fig. 1 is a prospective way to solve the problem. Heat pump is basically a heat engine run in the reverse direction. In other words, a heat pump is a device that is used to transfer heat energy to a thermal reservoir. They are often used to transfer thermal energy by absorbing heat from a cold space and releasing it to a warmer one.

The external source can be outside air, water (where available) or the ground. Air is the most widely used external source, but it presents several problems. In fact, its temperature is highly variable during the year and also during the day, and it is usually very low in cold climates and very high during the summer in warm climates. This implies that the efficiency of the HPs using air can be quite low. In addition, in cold climates with a high level of humidity, water

vapor can freeze on the external heat exchanger causing a severe decrease of the performance.

This implies that the efficiency of the HPs using air can be quite low. In addition, in cold climates with a high level of humidity, water vapor can freeze on the external heat exchanger causing a severe decrease of the performance. The cost effectiveness compared to the traditional systems according to the usual benefit-cost ratio standards has been estimated.

### 1.1 Energy and economic savings using geothermal heat pumps in different climates

The simplest thermodynamic sketch of HP stakes into account the interaction with two thermal reservoirs: one at high temperature and the other at low temperature. They represent the inside and outside environments interacting with the inverse cycle. The actual simplest cycle is made of four main components: the compressor, the evaporator, the condenser and the expansion valve. The condenser releases heat to the environment to be heated if the system works as an HP PILESIM2 software simulates the behavior of geothermal heat pump systems equipped with energy piles or boreholes.

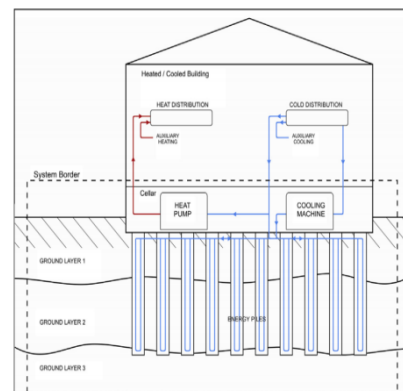

Figure 1: Pilesim of energy piles and reversible heat pump

### 1.2 Open Loop

The two main alternatives in solar cooling/heating systems are the photovoltaic (PV) driven heat pumps (HPs) and (ii) the solar driven sorption systems. The environmental

benefits of a solar driven adsorption system have been presented in a previous study by the authors. In fact, the reduction in the dependency from the conventional energy sources proved to be a key factor in the reduced footprint of the solar adsorption system compared to a heat pump driven by the grid.

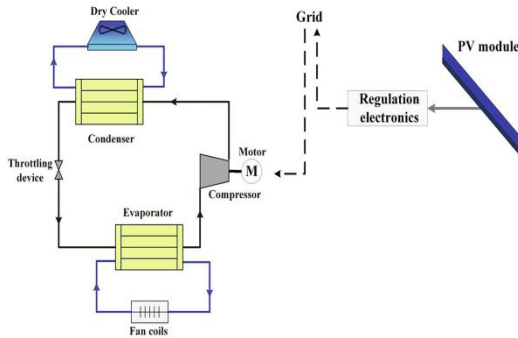

Figure 2: Photovoltaic driven heat pump

## II. METHODOLOGY

In heating mode, the outdoor coil becomes the evaporator, while the indoor becomes the condenser which absorbs the heat from the refrigerant and dissipates to the air flowing through it. The air outside even at 0 °C (or at any temperature above absolute zero) has heat energy in it. With the refrigerant flowing in the opposite direction the evaporator as shown in below fig 3 (outdoor coil) is absorbing the heat from the air and moving it inside. Once it picks up heat it is compressed and then sent to the condenser (indoor coil). The indoor coil then injects the heat into the air handler, which moves the heated air throughout the house. In cooling mode, the outdoor coil is now the condenser. This makes the indoor coil now the evaporator. The indoor coil is now the evaporator in the sense that it is going to be used to absorb the heat from inside the enclosed space. The evaporator absorbs the heat from the inside, and takes it to the condenser where it is rejected. The reversing valve switches the direction of refrigerant through the cycle and therefore the heat pump may deliver either heating or cooling to a building.

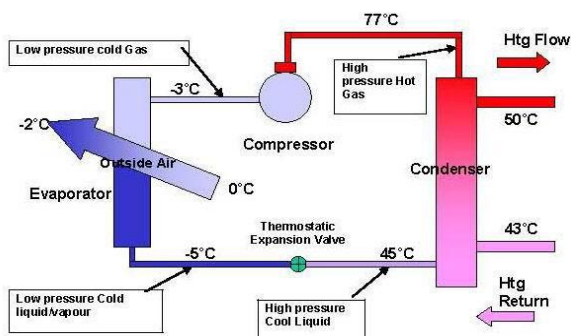

Figure 3: Heat pump of low pressure and high pressure

### 2.1 Biogas Engine-driven Heat Pump Air Conditioner

The core of the BHPAC (Biogas heat pump Air conditioner) system is a compression heat pump driven by a biogas engine. The hot water in the second heat exchanger is from the biogas engine and heated by the waste heat of engine. The outdoor new air mixed with the indoor air before the primary heat exchanger. Then the mixed air is treated by primary heat exchanger, second heat exchanger and water sprayed chamber before it is transmitted to the room.

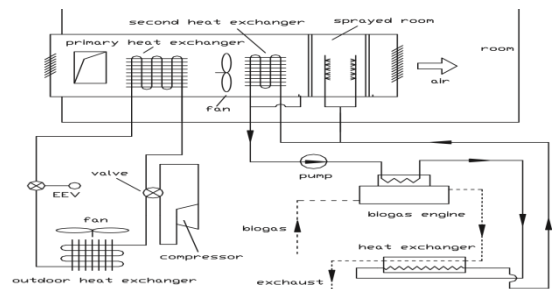

Figure 4: Primary return air BHP

### 2.2 water source heat pump for space heating using an outdoor pool as a heat source

Surface water and ground source heat pumps present higher stability and limited temperature decay. This configuration was analyzed by for both cooling and heating purposes. The availability of heating and cooling sources is considerable in winter and summer seasons, leading to higher seasonal performances when compared to the air source systems.

### 2.3 Compression heat pump systems with thermal energy storage for heating and cooling of buildings

In an experimental SAHP was enhanced with PCM storage to dampen heating and cooling load and to improve energy indicators at low ambient temperatures. The latter had a significant impact on the energy performance of the PCM-SAHP, whereas the chilled water flow rate had hardly any. The authors reported improvement of PCM-SAHP COP for 17% (cooling) and 65% (heating) compared to ASHP.

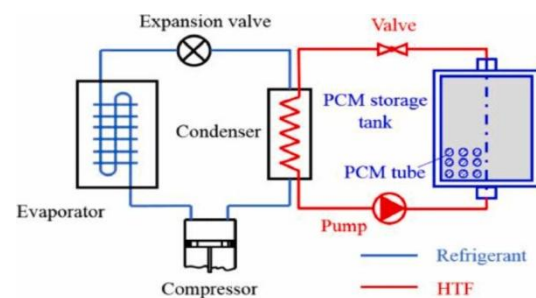

Figure 5: Schematic diagram of the heat collection and storage system

### III. RESULTS AND DISCUSSIONS

The performance of the proposed systems was studied regarding the electrical energy saving, natural gas saving, cost saving and emissions reduction, potentials in case of using it for cooling as well as space heating of the adjacent building.

However, the economic figures are not significantly high, since the benefits are mainly explained by the reduction on the partial load operation. In case of a further reduction on the prices of water source heat pumps such benefits could be high.

### IV. CONCLUSION

A cluster of new studies from states, electric utilities and environmental groups suggest that as more electricity from solar and wind power is introduced on the nation's electric grids, a wider use of electric heat pumps will help the United States reduce its greenhouse gas emissions to near zero by 2050.

Finally, by using the renewable sources for heating and cooling through heat pump will comparatively good with electrical heat pump because of ecofriendly nature and less CO<sub>2</sub> gas emissions. So, almost 30% of power should be saved for each house when using electricity to operate the heat pump, and it will be more profitable for both government and citizens.

### REFERENCES

- [1] Biagio Morrone , Gaetano Coppola, Vincenzo Raucci, "Energy and economic savings using geothermal heat pumps in different climates", energy conversion and management, volume: 88,DOI no:10.1016, pg no: 189-198, 2014.
- [2] Carolina Riva, Tryfon. Roumpedakis, George Kallis b, Matteo V, " Life cycle analysis of a photovoltaic driven reversible heat pump", Energy & Building, volume:240,DOI no:10.1016,pg no:110894-110911, 2021.
- [3] J.M. Cardemil, W. Schneider, M. Behzad, A.R. Starke, "Thermal analysis of a water source heat pump for space heating using an outdoor pool as a heat source", Building Engineer, volume no:158,DOI no:10.1016, pg no:101581-101596, 2020.
- [4] Mahdi Deymi-Dashtebayaz, Sajad Valipour-Namanlo, "Thermo economic and environmental feasibility of waste heat recovery of a data center using air source heat pump", Journal of Cleaner Production, volume no:219,DOI no:10.1016, pg no:117-126, 2019.
- [5] Eneja Osterman, Uros Stritih, "Review on compression heat pump systems with thermal energy storage for heating and cooling of buildings", journal of energy storage, volume no: 39, DOI no:10.1109, pg no:102569-102591, 2021.
- [6] Di Wu, Hongzhi Yan, Bin Hu, R.Z. Wang, "Modelling and simulation on a water vapor high temperature heat pump system", energy, volume no:45,DOI no:10.1019, pg no: 101567-101577, 2021.
- [7] Hongzhi Yan, Bin Hu, Ruzhu Wang, "Air-source heat pump heating based water vapor compression for localized steam sterilization applications during the COVID-19 pandemic", Renewable and Sustainable Energy, volume no:145,DOI no:10.1036, pg no:111026-111050, 2021.
- [8] Jan von Appen and Martin Braun, "Sizing and improved grid integration of residential PV systems with heat pumps and battery storage System", energy conversion, volume no: 34, DOI no:10.1109, pg no:2396-2411, 2019.
- [9] Riddhi.p. khinvasra, "Air Source Heat Pump", International Journal of Engineering Research Technology (IJERT), volume no:1, ISSUE no:8, pg no: 213-231, 2017.
- [10] Zhenjun Xu, Huaizhi Wu b,c Meiling Wu, "Energy performance and consumption for biogas heat pump air conditioner", Energy, volume no:35,DOI no:10.1016, pg no:5497-5502, 2019.

#### Citation of this Article:

T. Gopi Raju, B. Sai Murali Krishna, P. Sai Kiran, R. Naga Babu, V. Dileep Kumar, Ms.K. Bhargavi, "A Review on Working of Heat Pump with Different Natural Resources", published in *International Research Journal of Innovations in Engineering and Technology - IRJIET*, Volume 6, Issue 8, pp 132-134, August 2022. Article DOI <https://doi.org/10.47001/IRJIET/2022.608017>

\*\*\*\*\*