

Battery Monitoring System for Electric Vehicles

¹Karan Bhandari, ²Suyog Ghodekar, ³Harshada Kudale, ⁴Deep Shah, ⁵Prof. K. S. Khamkar

^{1,2,3,4}Student, Computer Science Engineering, RD' Shri Chhatrapati Shivajiraje College of Engineering, Dhangwadi, Bhore, Pune, Maharashtra, India

⁵Assistant Professor, Computer Science Engineering, RD' Shri Chhatrapati Shivajiraje College of Engineering, Dhangwadi, Bhore, Pune, Maharashtra, India

Abstract - Electric vehicles are the way of the future. The rising EV market, along with the diminishing supply of petroleum fuels, demands the development of more efficient EVs. A battery management system (BMS) is an essential component of any electric vehicle. It consists of a number of electrical and electronic circuits (including converter and inverter circuits) that have been programmed to monitor and extract the maximum output from a battery system. The chemical reactions are what determine the battery's performance. The performance of a battery degrades as chemicals decay. As a result, these features of a battery must be regularly monitored. Because of their high charge density and lightweight, Lithium-ion batteries have proven to be a popular choice among electric vehicle producers. Despite the fact that these batteries have a lot of power for their size, they are quite unstable. It is critical that these batteries are never overcharged or discharged, requiring the use of voltage and current regulators. In this research paper, we will monitor various aspects of the vehicles like current, Voltage, SOC and temperature with the help of NodeMCU which is the Wi-fi enabled microchip that will send the data or crucial parameters to the server which is the ThingSpeak. Therefore, in this way we can monitor these parameters from anywhere and also monitor battery health.

Keywords: Electric Vehicles, BMS, Lithium Ion Battery, Thingspeak, etc.

I. INTRODUCTION

Electric vehicles, which run on batteries rather than gas engines, are becoming more common. Electric vehicles are preferred by those who want to safeguard the environment and maybe go greener. However, many people are astonished to hear that electric vehicles are not a new technology. While it is unclear who invented the first electric car, electric motors were clearly in use as early as the 1800s. Around 1828, Anyos Jedlik invented the very first electric motor [1]. Using a small electric engine, he developed a self-moving tiny model automobile. A bigger electric motor designed by Scottish inventor Robert Anderson has been used to run a carriage between 1832 and 1839 [2].

American innovators returned to the electric car in the 20th century. William Morrison created what many consider to be the first practical electric car around this period, however it lacked range. During this period, hybrid vehicles were also developed to address a variety of concerns with electric vehicles.

Electric vehicles in the entire history have never been so in news, and a lot of them can drive many miles just by charging only once. In 2008, Tesla introduced the Roadster. Due to many hindrance and faults, it was being able to travel which was more than 200 km just by charging once. It was quickly followed by the Mitsubishi kilometres in Japan. The creation and introduction of these two cars, particularly Tesla, signalled the start of the modern era of electric vehicles. Other major automakers rapidly followed behind, developing evs of their own. A vast number of people had already created hybrids, suggesting that the method was well-established. The Chevrolet Volt was made by General Motors, and the Nissan Leaf was presented by Nissan. Smaller companies, such as Tesla, are pushing significant advancements in electric vehicles [3].

An electric car can be purchased for a variety of reasons. The motors are whisper quiet, and the trip is wonderfully relaxing. Since the power is sent directly to the wheels, the torque is higher than most people believe. There's no need to stop at a gas station, and while drivers must pay for the electricity needed to charge the car, it's less expensive than gasoline.

A battery pack is an arrangement of battery cells electronically arranged in a row x column matrix format to be able to produce a specified range of current and voltage for a given amount of time in response to projected load conditions. The following are common BMS responsibilities:

- Battery Monitoring
- Battery protection
- Estimating the operational state of the battery
- Constantly improving battery performance
- Reporting operational status to other devices

In this situation, the term "battery" refers to the entire pack; nevertheless, in the overall battery pack assembly, individual cells or clusters of cells known as modules are subjected to monitoring and control activities. Rechargeable lithium-ion cells have the highest energy density and are used in computer and electric car battery packs. They operate well, but if used outside of a relatively small safe operating area, they can be harsh, resulting in everything from battery degeneration to outright danger. The BMS does have a difficult job profile, and the complete complexity and oversight it requires may include digital, control, electrical, hydraulic, and thermal domains.

II. LITERATURE REVIEW

Title: "Battery Health Monitoring for Commercialized Electric Vehicle Batteries: Lithium-Ion"

Author: Fawad Ali Shah, Shehzad Shahzad Sheikh, Umar Iftikhar

Description: Batteries are widely utilized to power electric vehicles, hybrid electric vehicles (HEVs), and many other high-power applications. The battery is critical to their efficiency, safety, and reliability. Reliability. Initially, numerous types of batteries are discussed in this paper. According to the research, utilized in EVs and HEVs are explored. The most recent battery management methods (BMS). Lithium-ion batteries due of their extended life, a preferred source of EVs and HEVs high power density, and good charging and charging efficiency performance discharge However, there are still some concerns. Li-ion batteries are used in a variety of applications, including complicated electrochemistry, battery deterioration, and battery accuracy health assessment. Vehicle electrification is a global trend that includes Asia and Pakistan. Following that, the article considers the economic, environmental, and energy efficiency implications of increased use of electric vehicles [7].

Title: "Battery Swapping Technology"

Author: Shubham Jain, Azures Ahmad, Mohammad Saad Allam

Description: The transportation industry contributes significantly to carbon emissions and pollutes the environment globally. Electric vehicles (EVs) have a significant promise for reducing carbon emissions. A Battery Swapping Station (BSS) is a promising mechanism for providing power to EVs while reducing long charging times at a Battery Charging Station. Swapping Technology is an excellent option for completing a long-distance interstate journey. This study investigates the advantages of establishing the BSS from many perspectives, and as a result, a methodology for swapping out batteries in significantly less time is given, taking into account the position of the battery to be fixed. This new approach can

be used as a source of inspiration for a future framework that provides EVs with sensible and dependable charging [8].

Title: "Scalable and De-centralized Battery Management System for Parallel Operation Multiple Battery Packs"

Author: Shreyas Maitreyan, Himani Jain, Priyanka Pallial

Description: Multiple lithium-ion battery packs operating in parallel are required for large-scale energy storage applications. Renewable energy storage systems, battery packs for large-scale automobiles such as electric trucks, tanks, armoured vehicles, diesel-electric submarines, and so on are examples of such uses. The existing method for parallel operation of numerous battery packs is highly hardware intensive. It necessitates a distinct pack management system acting as a master, as well as battery management systems in each of the battery packs deployed as slaves. This has a huge impact on the scalability of such systems because the number of battery packs that can be connected in parallel is entirely reliant on the capacity of the master. A decentralised pack management system is presented as an alternative in this study. The suggested technique eliminates the need for master-slave battery pack configurations and eliminates the need for centralised hardware to manage the battery packs. Instead, this system allows individual Battery packs to communicate with one another on their own, allowing for decentralised pack administration [9].

Title: Battery Management System in Electric Vehicle

Author: Ananthraj C R, Arnab Ghosh

Description: The most crucial component of any electric vehicle (EV) is battery storage, which stores the energy required for the vehicle's operation. So, in order to get the most out of a battery while also ensuring its safety, it is vital to have an effective battery management system in place. It monitors the parameters, calculates SOC, and provides the services required to ensure the battery's safe functioning. As a result, BMS are a crucial component of any electric vehicle, and more research is being done in the field to build more capable BMS. System for Managing Batteries [10]

III. PROBLEM STATEMENT

Electric vehicles are popular for transportation in the current world and are taking the place of conventional vehicles since they provide a pollution-free environment. Several battery types, including lithium batteries, leadacid batteries, nickel-metal batteries, and solid-state batteries, are utilized in electric cars. The Lithium battery is the most recommended of these battery kinds. Since it is more efficient than conventional batteries and has a high energy content per unit of mass. It can also be recycled. In this study, an Internet of Things-based battery management system is suggested.

IV. METHODOLOGY

The system uses an Arduino as the microcontroller to control all of the components. It is using software Arduino IDE as a platform to make the coding. The theme of this project is to monitor the battery health. The methodology is divided into three parts.

The first part is on the design structure, followed by hardware description and the finally on the programming design.

All these three parts were assembled together and experiments were then performed to build a system that can observe and monitor the health of battery.

A battery management system is essentially the “brain” of a battery pack; it measures and reports crucial information for the operation of the battery and also protects the battery from damage in a wide range of operating conditions. Thus, a battery management system is necessary to observe battery conditions. As per the current world situation, the Internet of Things (IoT) are used in heterogeneous areas of research for supervising, congregating, and analyzing data from the remote locations of batteries. This system comprises numerous sensors for assessing the physical parameters. The parameters of the battery that can be assessed using these sensors are input voltage, current, temperature, and status of charging. Using this system, the real-time data can be determined and the data uploaded over the cloud is analyzed. Battery Management System is a system that monitors, balances, and protects a battery pack with four or more cells connected in series.

V. SYSTEM DESIGN

In the proposed system we are going to monitor Battery voltage, Battery temperature and current. By doing this we would be able to see voltage, current and temperature of the battery every very hour or every minute or whenever we would like.

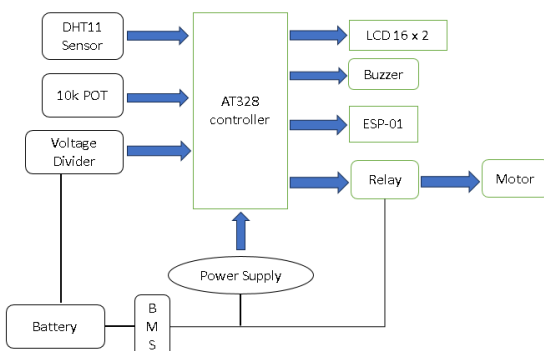

Figure 1: Block Diagram

When we replace the battery in an electric vehicle at a swapping station, there is no method to check the battery’s health card, including how much battery is depleted and how bad the battery is. In this way, anyone can offer us a used or defective battery, and we’ll have to accept it without knowing much about it. Since a result, battery prices will be compromised, as someone might pay more for a less efficient battery with a shorter life cycle than a more efficient battery with a longer life cycle. In this project we are going to use current sensor, voltage sensor and temperature sensor. We are going to connect the current sensor to the battery which would be eventually connected to the PMDC motor. We will do the same thing for temperature sensor and voltage sensor respectively. Then we will send the data to Arduino Cloud. Now when we will put the throttle on the all the three parameters will be sent to the Arduino cloud from where we will be able to read the data and get the various information.

Following figure shows the flowchart of the system:

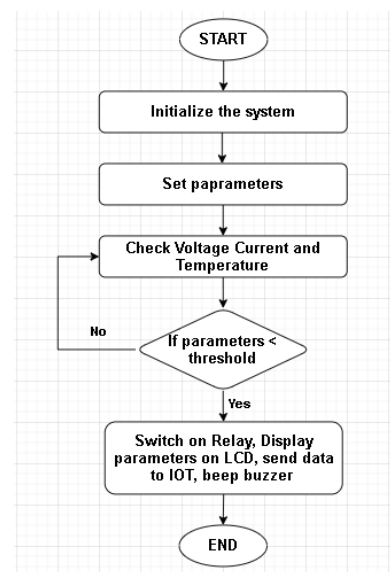

Figure 2: Flowchart

VI. ADVANTAGES AND APPLICATIONS

Advantages:

- Real-time monitoring
- Improved battery performance
- Longer battery lifespan
- Enhanced safety
- Efficient journey planning
- Remote monitoring and Control

Applications:

- Fleet management
- Predictive maintenance

- Charging optimization
- User interface
- Environmental monitoring
- Warranty tracking

VII. CONCLUSION

The proposed system is useful in monitoring and tracking the properties of the battery in real time. The battery plays a vital role in an Electric vehicle. Therefore, monitoring of the Battery is very important. The project proposed a new way monitoring the battery with the help IOT. The sensors incorporated in the proposed system can collect the data of battery such as voltage, temperature and current, these data are then sent to Arduino IOT Cloud. Thus the real time data collection, storage and monitoring of the battery of an electric vehicle is possible with the system. By tracking these variables, it will be easier to determine the battery's health or longevity, and pricing will be adjusted accordingly, as a less efficient battery with a shorter life cycle will cost more than a more efficient battery with a longer life cycle. This helps in identifying and solving a problem before a failure without human dependency. In addition, measured data helps to develop a battery swapping station and its price fixing.

REFERENCES

- [1] Babu, V.V.P., Reddy, K.S., Jadhav, L.V., Bhavana, I., Sridhar, G. and Reddy, M.S., 2021, February. Design, modelling and fabrication of 4-wheeler electric short commuter. In AIP Conference Proceedings (Vol. 2317, No. 1, p. 050014). AIP Publishing LLC.
- [2] Guarneri, M., 2012, September. Looking back to electric cars. In 2012 Third IEEE HISToRY of ELeCtro-technology CONference (HISTELCON) (pp. 1-6). IEEE.
- [3] Rajashekara, K., 2013. Present status and future trends in electric vehicle propulsion technologies. IEEE journal of emerging and selected topics in power electronics, 1(1), pp.3-10.
- [4] Denton, T., 2020. Electric and hybrid vehicles. Routledge.
- [5] Zhang, F., 2017. Modeling and control of a modular battery management system for lithium-ion battery packs (Doctoral dissertation, University of Colorado at Boulder).
- [6] Hemmati, M., Abapour, M. and Mohammadi-Ivatloo, B., 2020. Optimal scheduling of smart Microgrid in presence of battery swapping station of electrical vehicles. In Electric Vehicles in Energy Systems (pp. 249-267). Springer, Cham.
- [7] Shah, F.A., Sheikh, S.S., Mir, U.I. and Athar, S.O., 2019, August. Battery health monitoring for

commercialized electric vehicle batteries: Lithium-ion. In 2019 International Conference on Power Generation Systems and Renewable Energy Technologies (PGSRET) (pp. 1-6). IEEE.

- [8] S. Jain, Z. Ahmad, M. S. Alam and Y. Rafat, "Battery Swapping Technology," 2020 5th IEEE International Conference on Recent Advances and Innovations in Engineering (ICRAIE), 2020, pp. 1-4, doi: 10.1109/ICRAIE51050.2020.9358366.
- [9] Maitreya, S., Jain, H. and Paliwal, P., 2021, February. Scalable and De- centralized Battery Management System for Parallel Operation of Multiple Battery Packs. In 2021 Innovations in Energy Management and Renewable Resources (52042) (pp. 1-7). IEEE.
- [10] Ananthraj, C.R. and Ghosh, A., 2021, January. Battery Management System in Electric Vehicle. In 2021 4th Biennial International Conference on Nascent Technologies in Engineering (ICNTE) (pp. 1-6). IEEE.
- [11] Kur's, Andre; Moffatt, Robert; Solace, Marin, "Simultaneous midrange power transfer to multiple devices," Applied Physics Letters, vol.96, no.4, pp.044102, 044102-3.

AUTHORS BIOGRAPHY



Karan Bhandari,

Student, Computer Science Engineering, RD' Shri Chhatrapati Shivajiraje College of Engineering, Dhangwadi, Bhor, Pune, Maharashtra, India.



Suyog Ghodekar,

Student, Computer Science Engineering, RD' Shri Chhatrapati Shivajiraje College of Engineering, Dhangwadi, Bhor, Pune, Maharashtra, India.



Harshada Kudale,

Student, Computer Science Engineering, RD' Shri Chhatrapati Shivajiraje College of Engineering, Dhangwadi, Bhor, Pune, Maharashtra, India.



Deep Shah,

Student, Computer Science Engineering, RD' Shri Chhatrapati Shivajiraje College of Engineering, Dhangwadi, Bhor, Pune, Maharashtra, India.

Prof. K. S. Khamkar,
Assistant Professor, Computer Science
Engineering, RD' Shri Chhatrapati
Shivajiraje College of Engineering,
Dhangwadi, Bor, Pune, Maharashtra,
India.

Citation of this Article:

Karan Bhandari, Suyog Ghodekar, Harshada Kudale, Deep Shah, Prof. K. S. Khamkar, "Battery Monitoring System for Electric Vehicles", Published in *International Research Journal of Innovations in Engineering and Technology - IRJIET*, Volume 8, Issue 3, pp 378-382, March 2024. Article DOI <https://doi.org/10.47001/IRJIET/2024.803059>
