

# Motion Maverick

Agnish Samajpati

Diploma Student, Department of Electronics and Tele-Communication Engineering, Narula Institute of Technology, Kolkata, West Bengal, India

**Abstract** - The project is design to build an obstacle avoidance robotic vehicle using ultrasonic sensors for its movement with Bluetooth connectivity. A microcontroller (ATmega328) is used to achieve the desired operation. A robot is a machine that can perform task automatically or with guidance. The project proposes robotic vehicle that has an intelligence built in it such that it directs itself whenever an obstacle comes in its path. This robotic vehicle is built, using a micro-controller of ATmega 328 family. An ultrasonic sensor is used to detect any obstacle ahead of it and sends a command to the micro-controller. Depending on the input signal received, the micro-controller redirects the robot to move in an alternate direction by actuating the motors which are interfaced to it through a motor driver. Some of the project is built with the IR sensors has its own application so in our project those application is not compactable so we are using ultrasonic sensor.

**Keywords:** Arduino UNO, motor shield, ultrasonic sensor HC-SR04, TT Motor, servo motor, Bluetooth module.

## I. INTRODUCTION

From its initiation in the 1950s, modern robots have come a long way and rooted itself as an immutable aid in the advancement of humankind. In the course of time, robots took many forms, based on its application and its size varied from a giant 51 feet to microscopic level. The latter algorithms are more complex, since they involve detection of an obstacle as well as some kind of quantitative measurements concerning the obstacle's dimensions. Once these have been determined, the obstacle avoidance algorithm needs to steer the robot around the obstacle and resume motion toward the original target. In the course of technological developments of robots, one aspect remained instrumental to their function and that is mobility.

## II. OVERVIEW

Obstacle avoidance in robots can bring more flexibility in maneuvering in varying environments and would be much more efficient as continuous human monitoring is not required. This project also presents a dynamic steering algorithm which ensures that the robot doesn't have to stop in front of an obstacle which allows robot to navigate smoothly

in an unknown environment avoiding collisions. Meanwhile, PIR motion sensor needs a long calibration time and is sensitive to thermal radiation. Besides that, PIR sensor is insensitive to very slow motions or to objects in standing.

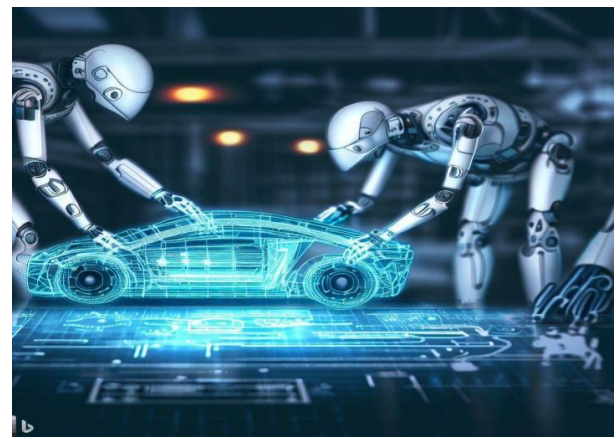

Figure 1: Use of AI in Car

## III. LITERATURE SURVEY

In the paper, "Obstacle Avoidance Robotic Vehicle Using Ultrasonic Sensor, Android and Bluetooth for Obstacle Detection" has been designed and developed by Agnish Samajpati, mentioned that enormous amount of work has been done on wireless gesture controlling of robots. Although, recent researches in this field have made wireless gesture controlling a ubiquitous phenomenon, it needs to acquire more focus in relevant areas of applications like home appliances, wheelchairs, artificial nurses, table top screens etc. in a collaborative manner.

Like this, a no. of works was scrutinized, only the base papers were considered & put here.

## IV. OBJECTIVE

Obstacle detection is considered as the primary requirement for an autonomous robot. A robotic car will avoid collisions and accidents.

The obstacle avoidance is an autonomous robot which is used for detecting the presence of an object or an obstacle and avoiding the collision that makes both the robot and the environment safe.

Effective obstacle detection can thus only be achieved via handling previously unseen objects.

To this end, existing methods generate synthetic training frames by injecting objects into the road scenes. However, they use random object sizes and locations.

### V. PROBLEM STATEMENT/SCOPE OF THE PROJECT

Robotics cars are a threat to life as sudden approach can't be detected so we are creating this obstacle avoiding sensor to detect that Privacy and security might get affected so it can be hacked.

It requires prior knowledge of the road and as well as how to operate that is the reason, we are building

It with minimal hardware objects so that it is easily accessible.

### VI. METHODOLOGY, BLOCK DIAGRAM

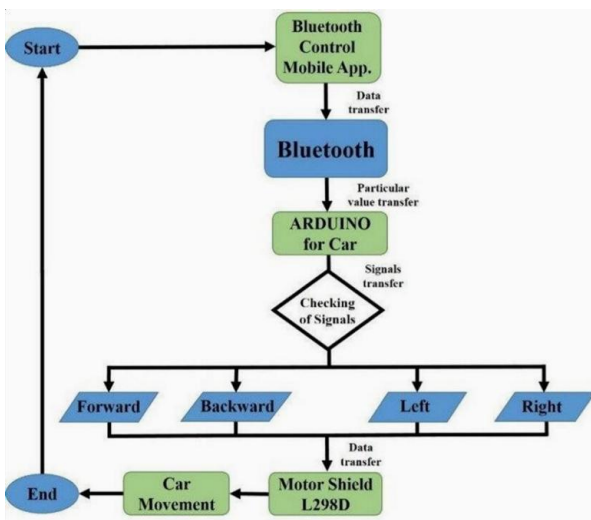

Figure 2: Flowchart

### VII. CIRCUIT DIAGRAM

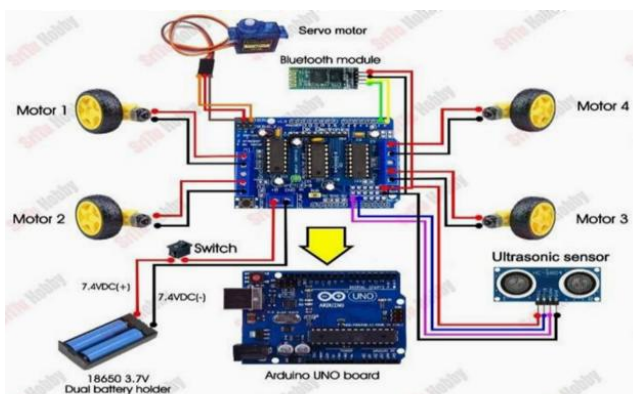

Figure 4: Overall circuit diagram used for the project work

### VIII. WORKING PRINCIPLE

In this project, the vehicle uses the ultrasonic sensor to detect objects. Initially the system starts with one sensor i.e ultrasonic, but as cars have some blind spots in it's left and right direction that is why two additional sensors were added to overcome the blind spot and limiting its chances of collision. Robot is designed in such a way that it detects the obstacle inside a particular range. Suppose there is something inside the range, then that is referenced as an obstacle the smart vehicle avoids it and changes its direction.

### IX. HARDWARE/SOFTWARE TOOLS USED

In this section, the hardware & software modules are presented for the developed project work.

#### Hardware

Hardware is a broad term that refers to all the physical parts that make up a computer. The internal hardware devices that make up the computer and ensure that it is functional are called components, while external hardware devices that are not essential to a computer's functions are called peripherals

The hardware that is used for the mini-project work are:

- Arduino UNO board
- Motor shield
- Ultrasonic sensor
- Bluetooth module
- Servo motor
- Gear motor
- Robot wheel
- Li-ion battery holder
- Li-ion battery
- Jumper wires
- Foam board or cardboard
- Switch

#### Software

Software is a set of instructions, data or programs used to operate computers and execute specific tasks. It is the opposite of hardware, which describes the physical aspects of a computer. Software is a generic term used to refer to applications, scripts and programs that run on a device. The software tool used for the mini-project work is,

- Arduino IDE (For programming)
- StriTu Hobby (For Bluetooth control)

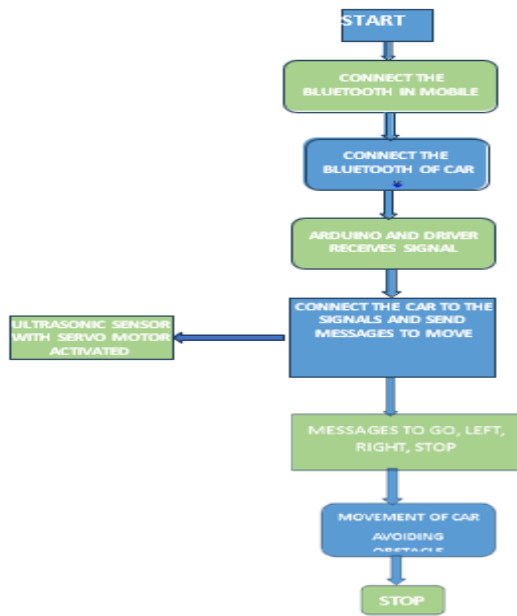

Figure 5: Flow-chart of methodology

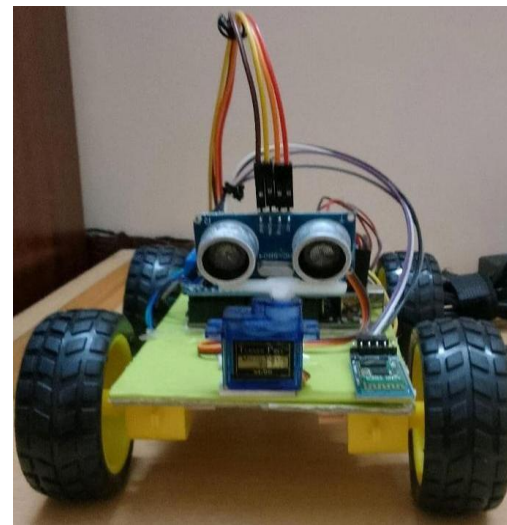

Figure 7: Model of the robotic vehicle developed - 2

**Note**

The Bluetooth module (HC-05) which is connected to the Arduino. As Arduino is programmable, so it have to be programmed using C, Java language. Hence it is easy to connect android application (AMR voice) and Bluetooth module (HC-05) using Bluetooth link.

**Working**

Stage 1: We connect the car to the Bluetooth or voice software app.

Stage 2: Once it is activated, we can now drive the car the way we want it to move.

Stage 3: The ultrasonic sensor detects the obstacle and stops itself from moving forward.

Stage 4: It then moves the other way where we want it to move.

**X. PHOTOGRAPHIC VIEW OF MODEL**



Figure 6: Model of the robotic vehicle developed - 1

**XI. RESULTS AND DISCUSSIONS**

- The results or the outcome of the mini-project work could be summarized as follows...
- The designed smartphone-controlled pick and place model. All the sensors are interfaced with Arduino board and fitted in the chassis using jumper wires.
- The gripper is attached at the top as shown. The simulation of the project is performed in Proteus Isis Professional Simulation software. The image of the simulation in the software along with the virtual window.
- The vehicle is controlled with instructions given by the user. Shows the controls used to give commands to the vehicle in the Cayenne software. Cayenne is an online IOT dashboard.
- The screen shows forward, backward, right, and left options to control the vehicle. Also, fire, temperature and gas symbols are there which indicates, if any of these are detected or not by the sensors in the vehicle.

**XII. APPLICATION, ADVANTAGES, DISADVANTAGES**

In this section, we present the applications, advantages, outcome and limitations of the project work.

**Applications**

- Automatic change over's of traffic signals.
- Counting instruments access switches parking meters especially military applications.
- It can be used for city wars.
- In robotics, Arduino is primarily used to control motors, sensors, and actuators.
- Motors are used to drive the movement of the robot and can be controlled with the Arduino's PWM (pulse width modulation) signals.

### Advantages

- The main advantage of this project is that it can detect and avoid, obstacle
- Collisions or accidents without disturbing it's work.
- It will make higher efficiency in traffic.
- It helps in identifying the hidden dangers of the blind spots.
- The sensory technology can perceive the environment better than the human senses. The robotic cars can see farther ahead.
- They can see better in poor visibility. They can detect smaller and more subtle obstacles and they can reduce traffic accidents.

### Outcome & Limitations

- Limited to small areas.
- Battery problem as it drain out when the system is in operation.

### XIII. CODE LINK BELOW (My Github account)

<https://github.com/Wgnk/robotcar1>

### XIV. CONCLUSION AND FUTURE WORK

Almost all navigation robot demands some sort of obstacle detection, hence obstacle avoidance strategy is of most importance. Obstacle Avoidance Robot has a vast field of application. They can be used as services robots, for the purpose of household work and so many other indoor applications. Equally they have great importance in scientific exploration and emergency rescue, there may be places that are dangerous for humans or even impossible for humans to reach directly, then we should use robots to help us. In those challenging environments, the robots need to gather information about their surroundings to avoid obstacles. The integration of voice reorganization system into robotics vehicle help disabled people. The speech control system,

though quite simple, shows the ability to apply speech reorganization techniques to control the application.

The method provides real-time operation, in this system android application is used to recognize human voice and is converted to text; the text is further processed and used to control robotics movements. During the project, the complete working of Arduino UNO and a variety of sensors is executed and understood. Coding and designing skills form the base and areutilized in the project. The project gives profound knowledge into different advancements and devices for improvement of the venture. Exposure to various software such as Arduino IDE and Proteus widened the knowledge in a broad aspect. There is much scope of improvement in the communication range and considerable reduction in processing time .

### REFERENCES

- [1] T.L. Chien H. Guo, K.L. Su and S.V. Shiau, "Develop a Multiple Interface Based Fire Fighting Robot", 2007 IEEE International Conference on Mechatronics, Changchun, Jilin, 2007, pp. 1-6, doi: 10.1109/ICMECH.2007.4280040, 2007.
- [2] S. Mandal, S.K. Saw, S. Maji, V. Das, S.K. Ramakuri and S. Kumar, "Low cost arduino wifi bluetooth integrated path following robotic vehicle with wireless GUI remote control", 2016 International Conference on Information Communication and Embedded Systems (ICICES), Chennai, pp. 1-5, 2016.
- [3] Zhao Wang, Eng Gee Lim, Weiwei Wang, M. Leach and Ka Lok Man, ""Design of an arduino- based smart car", International SoC Design Conference (ISOCC), Jeju, pp. 175-176, 2014.
- [4] N. Firthous Begum, P. Vignesh, "Design and Implementation of Pick and Place Robot with Wireless Charging Applications", International Journal of Science and Research (IJSR), ISSN (Online): 2319-7064, vol. 6, no. 7, pp. 56-67, 2013.

### Citation of this Article:

Agnish Samajpati. (2024). Motion Maverick. *International Research Journal of Innovations in Engineering and Technology - IRJIET*, 8(12), 183-186. Article DOI <https://doi.org/10.47001/IRJIET/2024.812027>

\*\*\*\*\*